

Pubs & Bars



All bars produced by Francis Catering Equipment are made to the highest standards by skilled craftsmen, with a **3 year parts and labour warranty** on in-house manufactured bar items.

Under-bars are made to order and to the individual design and dimensions of your bar.

Bar items are fully welded with robust design and manufacture that - unlike modular bars - allows them to be pulled out for easy cleaning.



Bespoke solutions that will **enhance** your bar

1. Stainless steel bar supports

Manufactured and fully welded in stainless steel with adjustable feet. Installed early in the project to allow services to be installed where necessary. Supports can be made for full height bars or low level for wheelchair access.

2. Ice chests

From 400mm up to 1200mm. Fully insulated with removable inserts to allow storage of ice, fruit juices and condiments.

3. Drop-in ice chests

Drop-in ice chests made for wooden or existing stainless steel bars. Chests are fully insulated.

4. Speed rails

Single or double rail for storage of regularly used spirits.

5. Glass storage units

With work top or drainer, normally with 3 shelves.

6. Bridging

Plain or draining worktop bridging solution - 300mm up to 1200mm.

7. Sinks

Single and double sinks with and without drainers.

8. Trolleys

Trolley for flash coolers.

9. Stainless steel Belfast Sink - fully insulated.

10. Speed rail for spirit measures to reduce theft.

11. Glass refreshers.

12. Ice chests with speed rail in line with glass storage units.

13. Stainless steel back bar for additional glass storage.

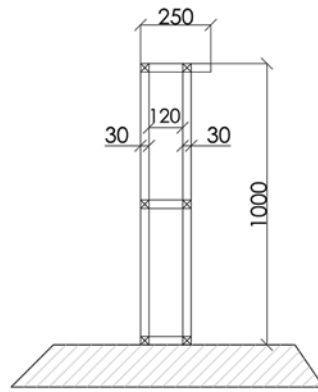

Designed for simple installation of all bar equipment. Fixing holes to top and bottom

1
1/2 BAR FRAME
SUPPORT



2



3



4

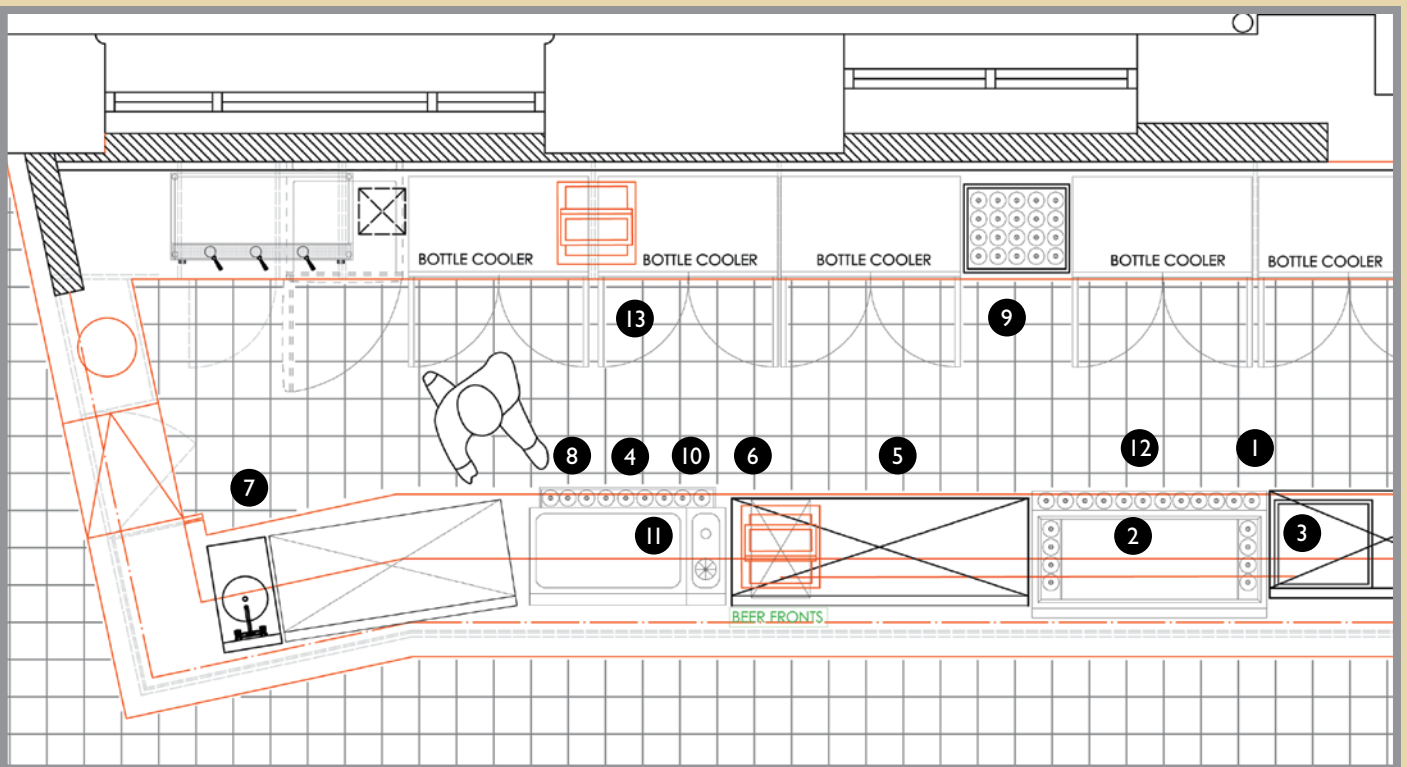

accessories

ICE MACHINES

Hoshizaki is widely considered to be one of the world's leading manufacturers of ice machines and is committed to providing an outstanding level of reliability and performance to ensure customers can depend on them season after season, year after year. The range encompasses many machines that make different types of ice for different users across a wide span of industry sectors. Hoshizaki has moved into a new 70,000 sq ft base on the Stafford Park industrial estate in Telford.



GLASS WASHERS

Meiko's compact and powerful Ecostar glass washing machines deliver the cleanest wash results - important for hectic back of bar locations where glassware is continuously rotated. Reliable, front-loading Ecostar models are fitted with Meiko's 'Eco Filter' to keep wash water cleaner, reduce detergent consumption and lower operating time and costs. All units are double skinned and insulated to keep heat within the warewasher, rather than 'leaking' out. For added safety, all models are cool to the touch.



BOTTLE COOLERS

The Maxi-glass cabinets are part of a comprehensive range of display cooling cabinets. Designed to meet the needs of today's professional bars where selling premium profit lines at the perfect temperature is crucial to the success of the bar. Gamko have one of the largest selections of finishes available in the UK market; including glass and solid doors and anthracite and stainless steel options.



Working towards ISO 9001

Francis Catering Equipment Ltd.

Unit 1, Lanesford Industrial Estate, Ham Lane,
Kingswinford, West Midlands DY6 7JU.

Tel: +44 (0)1384 271166

Fax: +44 (0)1384 273372

Service: +44 (0)1384 275757

e: info@franciscatering.com

www.franciscatering.com